

Fuel Saver

RETROKIT "NANO"

Lowers fuel consumption and pollution, smaller in size and price.

Weighing only 70 grams, Hypnow's mini catalytic reactor *Retrokit Nano* has intake and supply pipes of only 10mm in diameter. The unit mounts outside the exhaust pipe using only a clamp. Piping attachment uses included flexible hose. Two models are available ("Basic" and "Stainless" with included heat exchanger for cooling loop) .

Works with water.

■ **Retrokit Nano "Basic"** : with 1L (9x9x20 cm) clear moulded polypropylene bubbler - grooved for exterior heat exchanger.

■ **Retrokit Nano "Stainless"** : with 1L (10x10x20 cm) stainless steel bubbler, with interior stainless heat exchanger and reinforced hose.

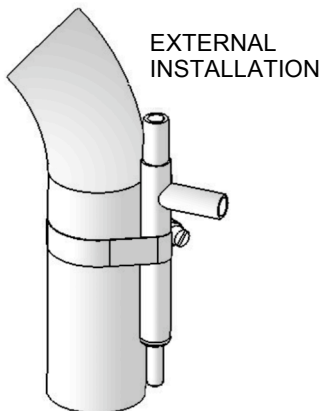

Performances

- From 5% to 25% savings of diesel fuel depending on engine and working conditions
- Lowers soot and smoke levels
- Extends engine life
- Reduces noise
- Quick installation



How it works

Ambient air (1) is sucked in the bubbler and makes humid air (3) by passing through the water (2). This aerosol is transformed by the reactor (4) into a synthetic gas (5) that mixes with the engine intake air (6) at the diffuser (7) in the intake pipe between the air filter and the turbo (8). The (now less polluting) exhaust gases (9) provide the energy necessary for the transformation.

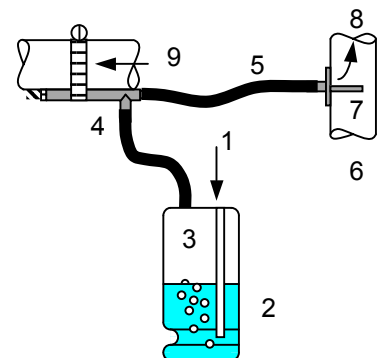

Applications

All diesel agricultural, industrial, maritime, or pump engines of less than 100 hp and not exceeding engine head volumes of 4500 cc (naturally aspirated) and 4000 cc (turbo).

Attention : The Retrokit Nano is not approved for on-road vehicles.

Though approval is not required in France for fuel savers (law : Arrêté du 26/02/1976 modifié le 26/12/1997), the improvement of the engine efficiency is significant. In case of installation on a vehicle, a title of acceptance from the competent authority is recommended. A written approval of the modifications from vehicle insurers **must be delivered**.

▲ *Respect the laws of the country of installation.*

HYPNOW and RETROKIT NANO are protected in the 163 signatory countries of the Berne Convention. Photos and drawings are non contractual. All rights reserved in all countries. © 2006 - 2010 - Dieulle - Tardy



HYPNOW SARL au capital de 13 000 € - RCS AIX 489 750 943 00016 - TVAIC : FR 49 489 750 943 - code APE 2899B
Siège social : Villa Mornaghia - Avenue Montfleuri - 13090 Aix en Provence - France
Fax +33 (0)811 480 213 - www.hypnow.fr - hypnow@hypnow.fr